

TIMING GEAR COVERS

CHEVROLET TIMING GEAR COVER

Chevrolet 265-283-327-350* & 400* cu in.

Includes bolts and water pump cam drive. Please specify cam drive needed (see below)



Item No.
875

***350 and 400 with small Harmonic Balancers - These will only fit a 7" diameter or below harmonic balancer.**

CHEVROLET TIMING GEAR COVER

Chevrolet 454 cu. in.

Mark V Aluminum 10 bolt cover for big block Chevrolet engines. Includes bolts, water pump cam drive and gasket. Please specify cam drive needed (see below)

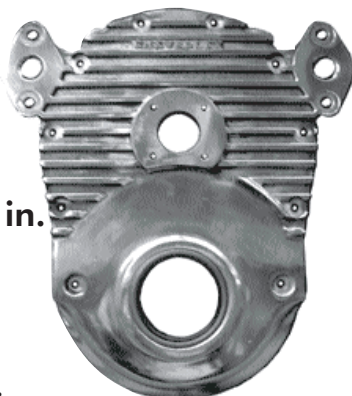

Item No.
936

Mark V

CHEVROLET TIMING GEAR COVER

Chevrolet 396 - 427 & 454 cu in.

Mark IV aluminum 10 bolt cover for big block Chevrolet engines. Includes bolts, water pump cam drive and gasket.

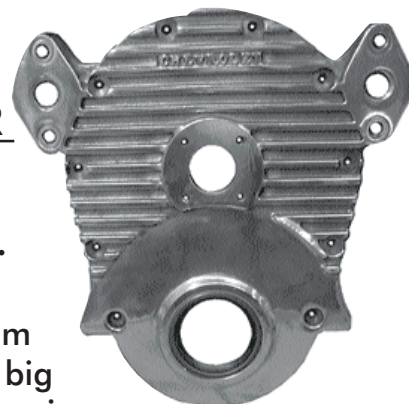

Item No.
935

Mark IV

CHEVROLET TIMING GEAR COVER

Chevrolet 454 - 502 cu. in.

Mark VI Aluminum 6 bolt cover for big block Chevrolet engines. Includes bolts, water pump cam drive and gasket. Please specify cam drive needed (see below)

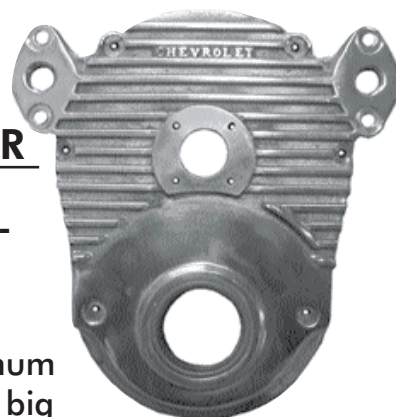

Item No.
937

Mark VI

Regular Chevy Cam Drive Specs

Bolt Circle: 1.360
Hole Spread: 1.178" or 1-3/16"

Roller Chevy Cam Drive Specs

Bolt Circle: 1.160
Hole Spread: 1.004" or 1"